



Arkansas Integrated Justice Information Systems Project

IJIS



**Improving Public Safety
and the
Administration of Justice
with Information Sharing**

**Faulkner County Pilot Project
Wrap-Up
April 1, 2004**



IJIS Goals

- Capture data once at source event
- Electronically share data with those who need it
- Eliminate redundant data entry
- Eliminate manual distribution of data
- Notify others of special events
- Make data available instantly to those who need it for ***effective decisions***



Pilot Project Purpose

- Provide a success to create synergy and support for the broader statewide integration
- Provide a learning opportunity
- Create a model for other counties to follow



Pilot Project Criteria

To provide a good test of integration

- Small enough for quick completion; large enough for proper test
- data exchanges among three or more systems of various complexity
- inclusion of a system on the state level;
- inclusion of a system that resides outside of the local area network.



Faulkner County Pilot Project

- **Focus on data sharing between:**
 - Faulkner County Sheriff's Office
 - 20th Judicial District Prosecuting Attorney
 - Faulkner County Circuit Clerk and Courts
 - Faulkner County Detention Facility
 - Dept. of Community Corrections
 - Dept. of Corrections



Automated Data Exchanges

1. Push Incident Data from Sheriff's Office to Prosecutor's Office
2. Share Court Dates between Court, Detention Facility, and Prosecutor's Office
3. Push Bail Information from Court to Jail
4. Push Fine Amounts from Court to Sheriff's Office



Automated Data Exchanges

5. Push Attorney Assignments between Prosecutor, Court, and Jail
6. Push Warrant Status between Sheriff's Office, Prosecutor's Office, and Circuit Clerk
7. Push Judgment & Disposition and Judgment & Commitment Data from Prosecutor's Office to the Department of Corrections and Department of Community Correction



Major Accomplishments

- Upgraded the local network and hardware
- Developed detailed business rules on how to share data
- Installed Transport Manager™
- Developed programs to access each system's database
- Gained understanding of each agency's data and business processes



Project Participants

1. ACIC
2. AOC
3. Dept. of Community Corrections
4. Dept. of Corrections
5. Prosecutor Coordinator's Office
6. State Police
7. Dept. of Information Systems
8. Executive CIO's Office
9. Sentencing Commission
10. Public Defender Commission
11. State Crime Lab
12. DHS Division of Youth Services
13. Sheriff's Office and Detention Facility
14. Prosecuting Attorney's Office
15. Circuit Clerk
16. Circuit Court
17. Templar Corp.
18. The Computer Works
19. M&M Micro Systems
20. PCO's Office (Jeff)
21. Marquis Software
22. Appriss, Inc.



Project Schedule

June 2002	Completed Agency Assessment
November 2002	Completed Initial Design and Scope Definition
February 2003	Completed Request for Proposals
July 2003	Contracted Templar Corp.
October 2003	Complete Detailed Requirements Document
November 2003	Completed Network & Hardware Upgrades
January 2004	Alpha Testing
February 2004	Beta Training
March 2004	System Accepted
April 1, 2004	GO LIVE!
April 5, 2004	Fail-over Setup



Arkansas Integrated Justice Information Systems Project

Network Upgrades



Network Upgrades

- 2 new servers
- 10 new switches and fiber modules
- 9 new patch panels
- 2 new 7 ft Equipment Racks and 1 rack mount
- Cabling upgrades
- Fiber Optic Network Backbone
 - Subnets for each agency



Arkansas Integrated Justice Information Systems Project





Arkansas Integrated Justice Information Systems Project





Arkansas Integrated Justice Information Systems Project





Arkansas Integrated Justice Information Systems Project





Arkansas Integrated Justice Information Systems Project

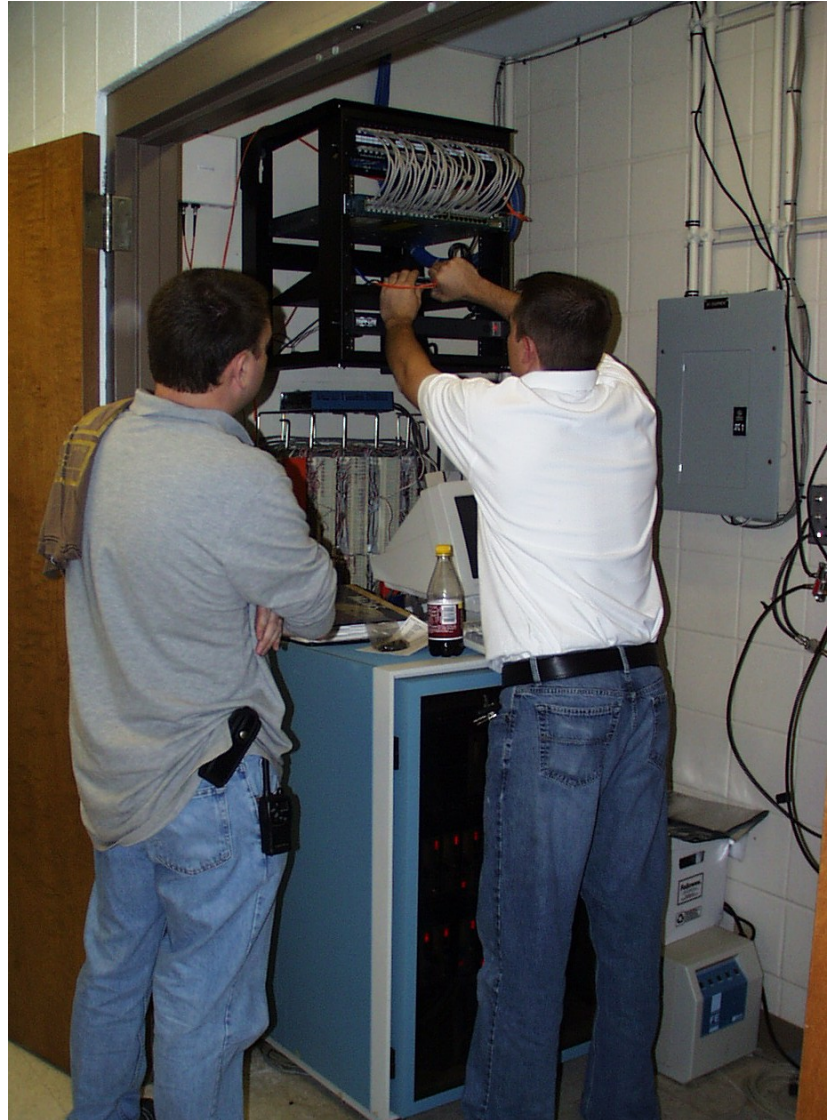



Arkansas Integrated Justice Information Systems Project





Arkansas Integrated Justice Information Systems Project



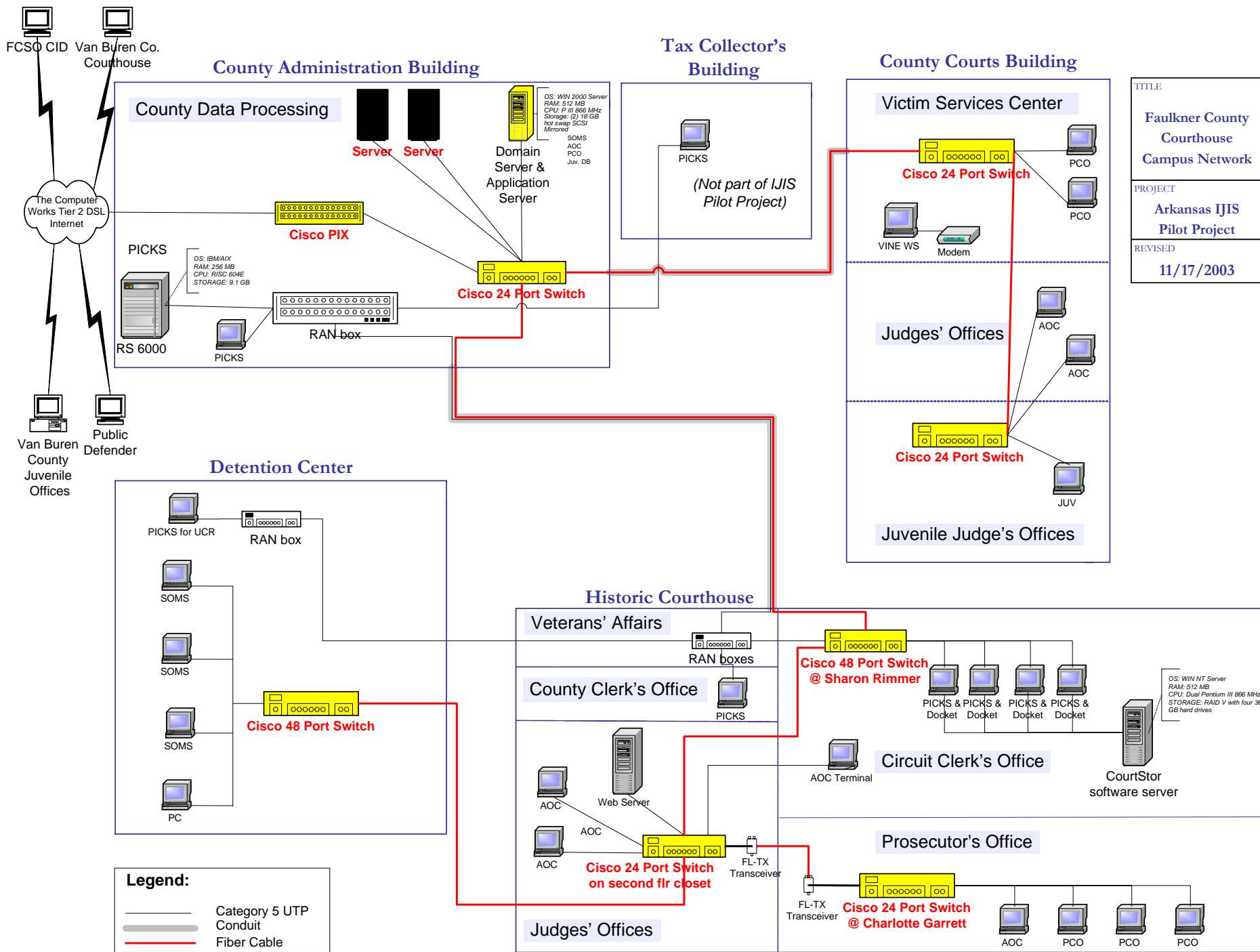

TITLE	Faulkner County Courthouse Campus Network
PROJECT	Arkansas IJIS Pilot Project
REVISED	11/17/2003



Arkansas Integrated Justice Information Systems Project

TRANSPORT MANAGER

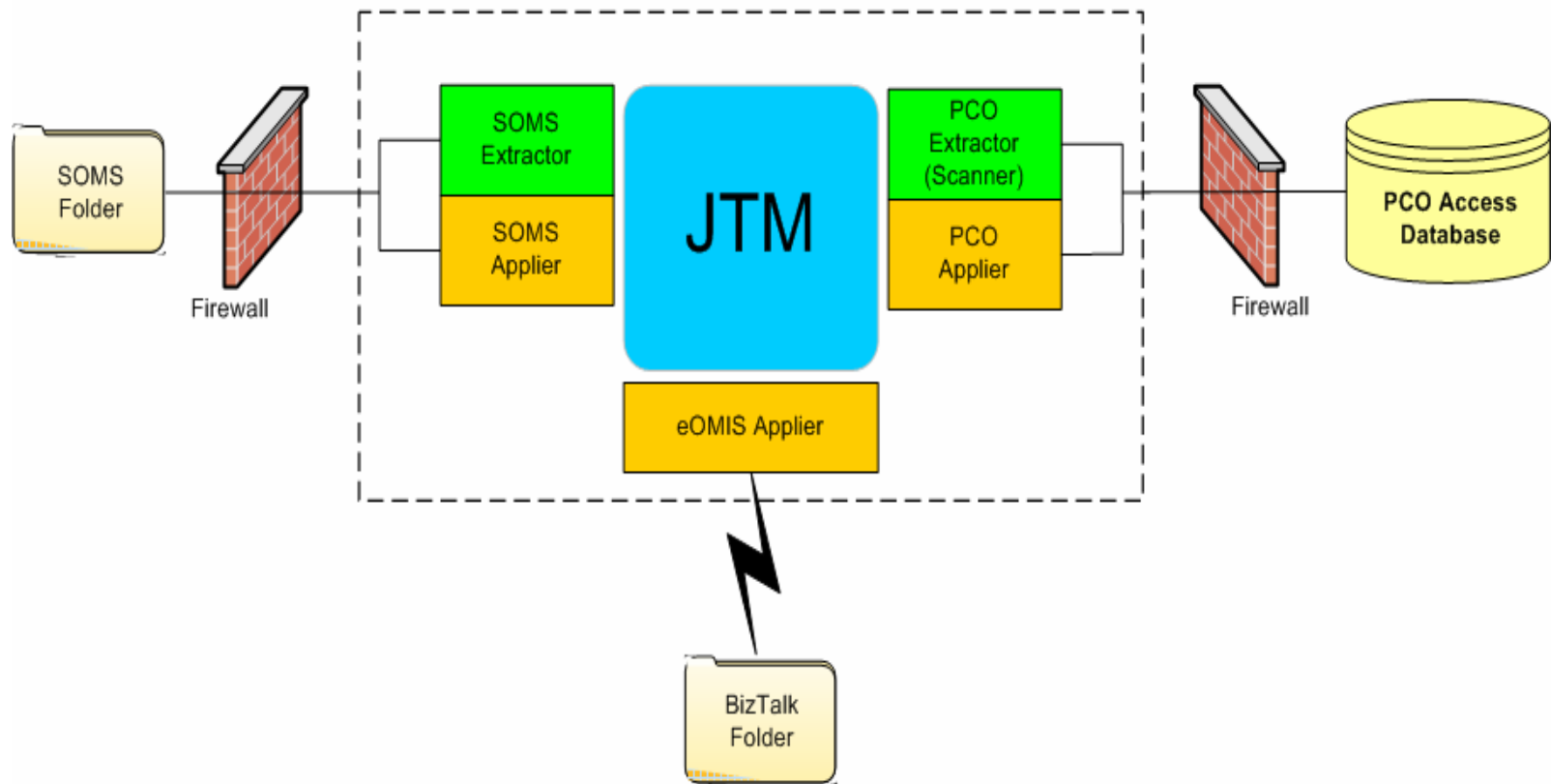



Extra Tasks Performed

PCO

- Added new fields, tables, and forms for Incident Data
 - Narrative, Location, Date From – Date Thru, Property Descriptions, Charge Descriptions, Firearm Information, Bond Amount, Release Date
- Added a Pending Flag
 - Notify Transport Manager that either a Judgment Commitment or Judgment Disposition is ready to be electronically sent to eOMIS



Extra Tasks Performed

SOMS

- Added the Agency Case Number on the Booking Charge Detail Screen
- Added a message indicating that the Incident Report has been sent to PCO
- Added an audit trail to the SOMS Booking Notes field



Extra Tasks Performed

Templar

- Created Email notifications to PCO Users for potential matching Subjects
- Linked Court Dates and Bonds to specific charges in SOMS Booking using Incident Number (agency case number).



Arkansas Integrated Justice Information Systems Project

Factors for Successful Operation



Agency Responsibilities

- Data Processing Office
 - Primary contact for network issues
 - Respond to issues in timely manner



Agency Responsibilities

- **Prosecutor's Office**
 - Because of the implementation delay of the new court system, the PA's Office has agreed to enter Court Date, Fines/Fees, and Attorney Assignments. This must be done in a timely manner for the IJIS system to be effective.
 - SID must be included in Judgment and Disposition/Commitment documents.



Agency Responsibilities

- Sheriff's Office and Detention Facility
 - It is critical that data is entered into SOMS in a timely manner for the system to be effective.
 - Must have Incident Number and Arrest Tracking Number when booking in suspects
 - Each charge in the booking record must have an incident number
 - Warrant number should be entered when booking in suspects



Agency Responsibilities

- ALL Agencies
 - Virus protection
 - Security
 - User IDs and confidential passwords
 - No modem connections on workstations
 - Keep current on software and hardware
 - Upgrade to Windows XP
 - Replace slow workstations
 - Implement a 3 year workstation upgrade plan
 - COMMUNICATE!



What's Next?

- Add more data exchanges!
 - Send prosecutor charging decisions to SOMS
 - Add Hot Checks processing
 - Send juvenile incidents and bookings from Sheriff to Juvenile RMS
- Add Conway Police Department
- Add other municipal police departments
- Expand to entire 20th Judicial District
- Include JIS when it becomes operational
- Add Public Defenders
- Send disposition, warrant, and protection order data to ACIC
- Install Informant™



Arkansas Integrated Justice Information Systems Project

Brenda Barber

Ark. IJIS Project Director

1 Capitol Mall, 2D400

Little Rock, AR 72201

501.682.0053

bbarber@acic.state.ar.us

www.ijis.state.ar.us



Arkansas Integrated Justice Information Systems Project

Demonstration